

WellDisk Technology Corp.

SATA DOM

Datasheet

WSDS32-XXXXX

Version A1.3



| | | |
|-----------|-------------------------------------------|-----------|
| 1. | Introduction | 5 |
| 1.1. | General Description | 5 |
| 1.2. | Block Diagram | 5 |
| 2. | Product Specifications..... | 6 |
| 3. | Environmental Specifications | 9 |
| 3.1. | Environmental Conditions | 9 |
| 3.1.1. | Temperature and Humidity | 9 |
| 3.1.2. | Shock..... | 10 |
| 3.1.3. | Vibration..... | 10 |
| 3.1.4. | Drop | 10 |
| 3.1.5. | Bending | 11 |
| 3.1.6. | Electrostatic Discharge (ESD) | 11 |
| 3.2. | MTBF..... | 11 |
| 3.3. | Certification | 11 |
| 3.4. | Compliance | 11 |
| 4. | Electrical Specifications | 12 |
| 4.1. | Supply Voltage..... | 12 |
| 4.2. | Power Consumption..... | 12 |
| 5. | Interface..... | 13 |
| 5.1. | Pin Assignment and Descriptions | 13 |
| 6. | Supported Commands..... | 14 |
| 6.1. | ATA Command List..... | 14 |
| 6.2. | Identify Device Data | 16 |
| 7. | Physical Dimension | 20 |
| 8. | Terminology | 21 |
| 9. | Partnumber decoder | 22 |

Revision History

| Revision | Draft Date | History | Author |
|----------|------------|-------------|------------|
| 1.0 | 2018/2/23 | New release | Golden Lee |
| | | | |



Product Overview

- **Capacity**
 - MLC: 4GB up to 16GB
 - 3D TLC: 16GB up to 64GB
- **SATA Interface**
 - SATA Revision 3.2
 - SATA 1.5Gbps, 3Gbps, and 6Gbps interface
- **Flash Interface**
 - Flash Type: MLC / 3D TLC
- **Performance**
 - Read up to 330 MB/s
 - Write up to 220 MB/s
- **Power Consumption**^{Note1}
 - Active mode: < 990 mW
 - Idle mode: < 310 mW
- **TBW (Terabyte Written)**^{Note2}
 - MLC: 6 TBW for 16GB
 - 3D TLC: 74 TBW for 64GB
- **MTBF**
 - MLC/3D TLC: 2,000,000 hours
- **Advanced Flash Management**
 - Static and Dynamic Wear Leveling
 - Bad Block Management
 - TRIM
 - SMART
 - Over-Provision
- **Low Power Management**
 - DIPM/HIPM Mode
 - DEVSLP Mode (Optional)
- **Temperature Range**
 - Operation (Standard): 0°C ~ 70°C
 - Operation (Wide): -40°C ~ 85°C
 - Storage: -40°C ~ 85°C
- **Compliant**
 - RoHS
 - CE & FCC

Notes:

1. Please see “Power Consumption” for details.
2. Please see “TBW (Terabytes Written)” in chapter 2 for details.



1. INTRODUCTION



1.1. General Description

Welldisk's SATA Flash Module delivers all the advantages of flash disk technology with the Serial ATA III interface. It is designed with the form factor of 7-Pin SATA signals and could be mounted directly to Host without any effort. Welldisk's SATA Flash Module can operate at a maximum operating frequency of 200MHz with 30MHz external crystal. Its capacity could provide a wide range up to 64GB. Moreover, it can reach up to 330MB/s read as well as 220MB/s write high performance based on Toshiba NAND flash (with 32MB SDR enabled and measured by CrystalDiskMark v5.0).

1.2. Block Diagram

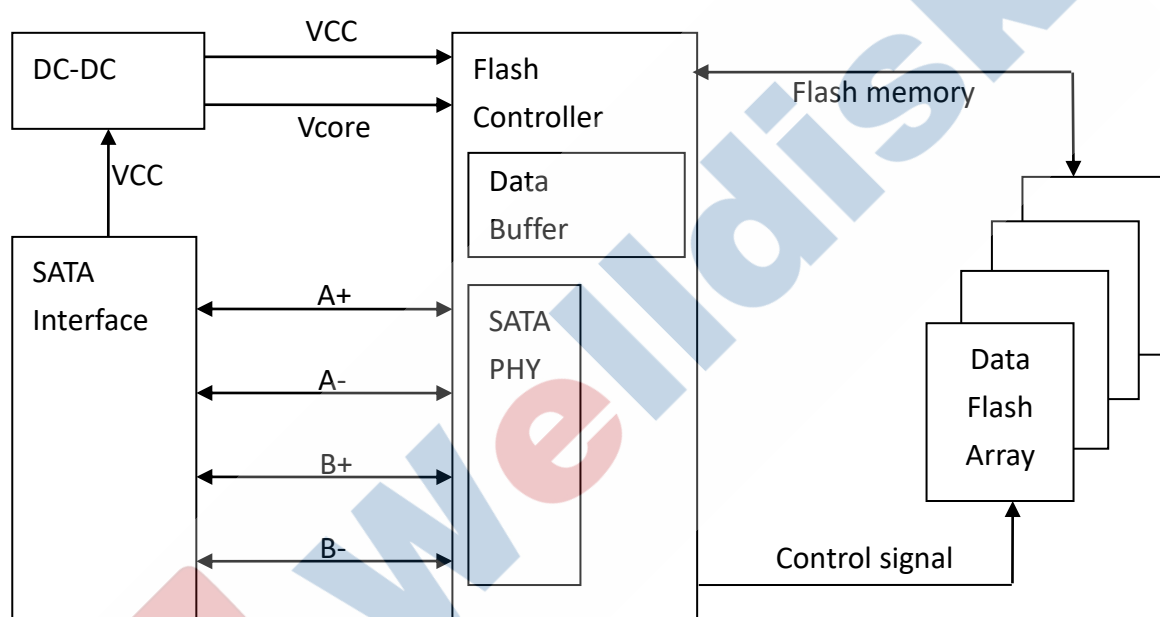

SATA Flash Module Block Diagram

2. PRODUCT SPECIFICATIONS



- **Capacity**
 - MLC: From 4GB up to 16GB (support 48-bit addressing mode)
 - 3D TLC: From 16GB up to 64GB (support 48-bit addressing mode)
- **Electrical/Physical Interface**
 - SATA Interface
 - ◆ Compliant with SATA Revision 3.2
 - ◆ Compatible with SATA 1.5Gbps, 3Gbps and 6Gbps interface
 - ◆ Support power management
 - ◆ Support expanded register for SATA protocol 48 bits addressing mode
 - ◆ Embedded BIST function for SATA PHY for low cost mass production
- **Built-in 2-channel NAND flash interface controller**
 - Compliant with Toggle 1.0 and Toggle 2.0 NAND Flash interface
 - Compliant with ONFI 4.0 interface:
 - ◆ SDR up to mode 5
 - ◆ NV-DDR up to mode 5
 - ◆ NV-DDR2 up to mode 7
 - ◆ NV-DDR3 up to mode 8
- **Supported NAND Flash**
 - Support up to 16 Flash Chip Enables (CE) within single design
 - Toshiba 15nm/3D-NAND MLC and TLC
 - Intel/Micron 16nm/3D-NAND MLC and TLC
 - Hynix 16nm/3D-NAND
 - Support all types of SLC/MLC/TLC/3D-NAND, 8KB/page and 16K/page NAND flash
 - Support ONFI 2.3, ONFI 3.0, ONFI 3.2 and ONFI 4.0 interface: 2 channels at maximum
- **ECC Scheme**
 - Applies the LDPC (Low Density Parity Check) of ECC algorithm
- **UART function**
- **GPIO**
- **Support SMART and TRIM commands**

- **Capacity Information**

| Capacity | Cylinders | Heads | Sectors | Total Sectors | User Data Size |
|----------|-----------|-------|---------|---------------|-----------------------------|
| 2GB | 3,897 | 16 | 63 | 3,928,176 | Depended on file management |
| 4GB | 7,773 | 16 | 63 | 7,835,184 | |
| 8GB | 15,525 | 16 | 63 | 15,649,200 | |
| 16GB | 16,383 | 16 | 63 | 31,277,232 | |
| 32GB | 16,383 | 16 | 63 | 62,533,296 | |
| 64GB | 16,383 | 16 | 63 | 125,045,454 | |

- **Performance**

- **MLC:**

| Capacity | Flash Structure | Flash Type | Sequential | |
|----------|-----------------|------------|-------------|--------------|
| | | | Read (MB/s) | Write (MB/s) |
| 4GB | 4GB x 1 | 15nm, TSOP | 150 | 50 |
| 8GB | 8GB x 1 | 15nm, TSOP | 160 | 90 |
| 16GB | 16GB x 1 | 15nm, TSOP | 300 | 75 |

- **3D TLC:**

| Capacity | Flash Structure | Flash Type | Sequential | |
|----------|-----------------|-----------------|-------------|--------------|
| | | | Read (MB/s) | Write (MB/s) |
| 16GB | 16GB x 1 | TSB Bics3, TSOP | 290 | 125 |
| 32GB | 32GB x 1 | TSB Bics3, TSOP | 290 | 125 |
| 64GB | 64GB x 1 | TSB Bics3, TSOP | 330 | 220 |

Notes:

1. The performance was estimated based on Toshiba NAND flash.
2. Performance may differ according to flash configuration and platform.
3. The table above is for reference only.

- **TBW (Terabytes Written)**

- **MLC:**

| Capacity | Flash Structure | TBW |
|----------|-----------------|-----|
| 4GB | 4GB x 1 | 1 |
| 8GB | 8GB x 1 | 3 |
| 16GB | 16GB x 1 | 6 |

- **3D TLC:**

| Capacity | Flash Structure | TBW |
|----------|-----------------|-----|
| 16GB | 16GB x 1 | 18 |
| 32GB | 32GB x 1 | 36 |
| 64GB | 64GB x 1 | 74 |

Notes:

1. Samples were built using Toshiba NAND flash.
2. TBW may differ according to flash configuration and platform.
3. The endurance of SSD could be estimated based on user behavior, NAND endurance cycles, and write amplification factor. It is not guaranteed by flash vendor.



3. ENVIRONMENTAL SPECIFICATIONS



3.1. Environmental Conditions

3.1.1. Temperature and Humidity

- Temperature:
 - ◆ Storage: -40°C to 85°C
 - ◆ Operational (Standard grade): 0°C to 70°C
 - ◆ Operational (Wide grade): -40°C to 85°C
- Humidity:
 - ◆ Standard grade: RH 90% under 40°C (operational)
 - ◆ Wide grade: RH 95% under 55°C (operational)

■ High Temperature Test Condition

| | Temperature | Humidity | Test Time |
|-----------------------------|-------------|----------|-----------|
| Operation (Standard) | 70°C | 0% RH | 72 hours |
| Operation (Wide) | 85°C | 0% RH | 72 hours |
| Storage (Standard) | 85°C | 0% RH | 72 hours |
| Storage (Wide) | 85°C | 0% RH | 168 hours |

Result: No any abnormality is detected.

■ Low Temperature Test Condition

| | Temperature | Humidity | Test Time |
|-----------------------------|-------------|----------|-----------|
| Operation (Standard) | 0°C | 0% RH | 72 hours |
| Operation (Wide) | -40°C | 0% RH | 72 hours |
| Storage (Standard) | -40°C | 0% RH | 72 hours |
| Storage (Wide) | -40°C | 0% RH | 168 hours |

Result: No any abnormality is detected.

■ High Humidity Test Condition

| | Temperature | Humidity | Test Time |
|-----------------------------|-------------|----------|-----------|
| Operation (Standard) | 40°C | 93% RH | 24 hours |
| Operation (Wide) | 55°C | 95% RH | 72 hours |
| Storage (Standard) | 40°C | 95% RH | 72 hours |
| Storage (Wide) | 55°C | 95% RH | 96 hours |

Result: No any abnormality is detected.

Temperature Cycle Test

| | Temperature | Test Time | Cycle |
|-----------------------------|-------------|-----------|-----------|
| Operation (Standard) | 0°C | 30 min | 10 cycles |
| | 70°C | 30 min | |
| Operation (Wide) | -40°C | 30 min | 20 cycles |
| | 85°C | 30 min | |
| Storage (Standard) | -40°C | 30 min | 10 cycles |
| | 85°C | 30 min | |
| Storage (Wide) | -40°C | 30 min | 50 cycles |
| | 85°C | 30 min | |

Result: No any abnormality is detected.

3.1.2. Shock
Shock Specification

| | Acceleration Force | Half Sin Pulse Duration |
|------------------------|--------------------|-------------------------|
| Non-Operational | 1500G | 0.5ms |
| Operational | 1500G | 0.5ms |

Result: No any abnormality is detected when power on.

3.1.3. Vibration
Vibration Specification

| | Condition | | Vibration Orientation |
|--------------------|------------------------|------------------------|------------------------------|
| | Frequency/Displacement | Frequency/Acceleration | |
| Operational | 20Hz~80Hz/1.52mm | 80Hz~2000Hz/20G | X, Y, Z axis/60 min for each |

Result: No any abnormality is detected when power on.

3.1.4. Drop
Drop Specification

| | Height of Drop | Number of Drop |
|------------------------|----------------|-----------------------------------|
| Non-operational | 80cm free fall | 6 face of each unit, 2 times each |

Result: No any abnormality is detected when power on.

3.1.5. Bending

■ Bending Specification

| | Force | Action |
|-----------------|-------|------------------|
| Non-operational | ≥ 20N | Hold 1min/5times |

Result: No any abnormality is detected when power on.

3.1.6. Electrostatic Discharge (ESD)

■ Contact ESD Specification

| Device | Capacity | Temperature | Relative Humidity | +/- 4KV | Result |
|-------------|----------|-------------|-------------------|-------------------------------------------------------------------------------------------------------|--------|
| SATA Module | 64GB | 24.0°C | 49% (RH) | Device functions are affected, but EUT will be back to its normal or operational state automatically. | PASS |

3.2. MTBF

MTBF, an acronym for Mean Time between Failures, is a measure of a device's reliability. Its value represents the average time between a repair and the next failure. The measure is typically in units of hours. The higher the MTBF value, the higher the reliability of the device. The predicted result of WellDisk's SATA SSD is up to 2,000,000 hours.

3.3. Certification

- RoHS
- CE / FCC

3.4. Compliance

- SATA III (SATA Rev. 3.2)
- Up to ATA/ATAPI-8 (Including S.M.A.R.T)

4. ELECTRICAL SPECIFICATIONS



4.1. Supply Voltage

| Parameter | Rating |
|-------------------|-------------|
| Operating Voltage | 5V \pm 5% |

4.2. Power Consumption

▪ MLC

| Capacity | Flash Structure | Flash Type | Read | Write | Partial | Slumber | Idle | DEVSLP |
|----------|-----------------|------------|------|-------|---------|---------|------|--------|
| 4GB | 4GB x 1 | 15nm, TSOP | 780 | 780 | 18 | 13 | 300 | 4.9 |
| 8GB | 8GB x 1 | 15nm, TSOP | 800 | 850 | 19 | 13 | 310 | 4.9 |
| 16GB | 16GB x 1 | 15nm, TSOP | 990 | 790 | 18 | 12 | 310 | 4.9 |

Unit: mW

▪ 3D TLC

| Capacity | Flash Structure | Flash Type | Read | Write | Partial | Slumber | Idle | DEVSLP |
|----------|-----------------|-----------------|------|-------|---------|---------|------|--------|
| 16GB | 16GB x 1 | TSB Bics3, TSOP | 930 | 835 | 14 | 9 | 265 | 4.9 |
| 32GB | 32GB x 1 | TSB Bics3, TSOP | 950 | 850 | 14 | 9 | 265 | 4.9 |
| 64GB | 64GB x 1 | TSB Bics3, TSOP | 975 | 900 | 14 | 9 | 265 | 4.9 |

Unit: mW

Notes:

1. It's average value of power consumption is achieved based on 100% conversion efficiency.
2. The measured power voltage is 5V.
3. Samples were built using Toshiba NAND flash and measured under normal temperature.
4. Sequential R/W is measured while testing 4000MB sequential R/W 5 times by CrystalDiskMark.
5. Power Consumption may differ according to flash configuration and platform.

5. INTERFACE



5.1. Pin Assignment and Descriptions

- SATA Connector

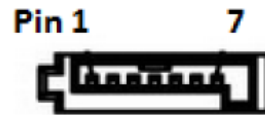



SATA Flash Module

| Pin # | Segment | Pin Definition | Description |
|-------|---------|----------------|-------------------------------------------|
| 1 | SATA | GND | Ground for signal integrity |
| 2 | SATA | A+ | Host Transmitter Differential Signal Pair |
| 3 | SATA | A- | Host Transmitter Differential Signal Pair |
| 4 | SATA | GND | Ground for signal integrity |
| 5 | SATA | B- | Host Receiver Differential Signal Pair |
| 6 | SATA | B+ | Host Receiver Differential Signal Pair |
| 7 | SATA | GND | Ground for signal integrity |

- Power Head & WP Switch

2-Pin, Pitch: 1.25mm

Write Protection Switch Function

| | |
|-------------------------------------------------------------------------------------|------------------------------|
|  | Normal |
|  | Write Protection (Read Only) |

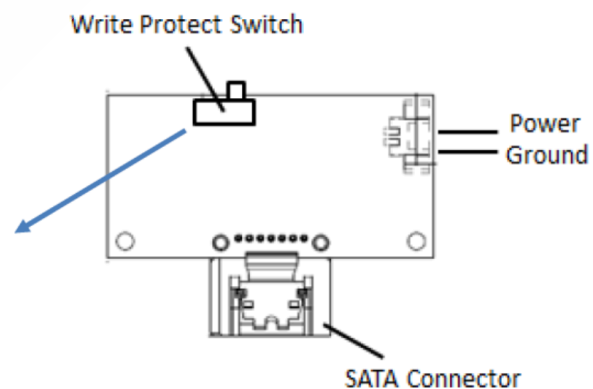

WellDisk Technology Co., Ltd.

layer 318 new material chuanyue building Feng Hui middle road no.7 Beijing haidian district TEL: +86-010-56298618 E-mail: sales@welldisk.com

6. SUPPORTED COMMANDS



6.1. ATA Command List

| Op-Code | Command Description | Op-Code | Command Description | |
|---------|-----------------------------------|-----------------------------------|------------------------------|-----------------------------------------|
| 00h | NOP | 60h | Read FPDMA Queued | |
| 06h | Data Set Management | 61h | Write FPDMA Queued | |
| 10h | Recalibrate | 70h | Seek | |
| 20h | Read Sectors | 90h | Execute Device Diagnostic | |
| 21h | Read Sectors without Retry | 91h | Initialize Device Parameters | |
| 24h | Read Sectors EXT | 92h | Download Microcode | |
| 25h | Read DMA EXT | 93h | Download Microcode DMA | |
| 27h | Read Native Max Address EXT | B0h | SMART | |
| 29h | Read Multiple EXT | B0h | D0h | SMART READ DATA |
| 2Fh | Read Log EXT | B0h | D1h | SMART READ DATA ATTRIBUTE THRESHOLD |
| 30h | Write Sectors | B0h | D2h | SMART ENABLE/DISABLE ATTRIBUTE AUTOSAVE |
| 31h | Write Sectors without Retry | B0h | D3h | SMART SAVE ATTRIBUTE VALUES |
| 34h | Write Sectors EXT | B0h | D4h | SMART EXECUTE OFF-LINE IMMEDIATE |
| 35h | Write DMA EXT | B0h | D5h | SMART READ LOG |
| 37h | Set Native Max Address EXT | B0h | D6h | SMART WRITE LOG |
| 39h | Write Multiple EXT | B0h | D8h | SMART ENABLE OPERATIONS |
| 3Dh | Write DMA FUA EXT | B0h | D9h | SMART DISABLE OPERATIONS |
| 3Fh | Write Long EXT | B0h | DAh | SMART RETURN STATUS |
| 40h | Read Verify Sectors | B0h | DBh | SMART ENABLE/DISABLE AUTOMATIC OFF-LINE |
| 41h | Read Verify Sectors without Retry | B1h | | DEVICE CONFIGURATION OVERLAY |
| 42h | Read Verify Sectors EXT | B1h | C0h | DEVICE CONFIGURATION RESTORE |
| 45h | Write Uncorrectable EXT | B1h | C1h | DEVICE CONFIGURATION FREEZE LOCK |
| 47h | Read Log DMA EXT | B1h | C2h | DEVICE CONFIGURATION IDENTIFY |
| 57h | Write Log DMA EXT | B1h | C3h | DEVICE CONFIGURATION SET |
| B1h | C4h | DEVICE CONFIGURATION IDENTIFY DMA | ECh | Identify Device |
| B1h | C5h | DEVICE CONFIGURATION SET DMA | EFh | Set Features |
| C4h | Read Multiple | EFh | 02h | Enable 8-bit PIO transfer mode |

| Op-Code | | Command Description | Op-Code | | Command Description |
|---------|-----|---------------------------------------|---------|---------|-------------------------------------------------------------------|
| C5h | | Write Multiple | EFh | 03h | Set transfer mode based on value in Count field |
| C6h | | Set Multiple Mode | EFh | 05h | Enable advanced power management |
| C8h | | Read DMA | EFh | 10h | Enable use of Serial ATA feature |
| C9h | | Read DMA without Retry | EFh | 10h 02h | Enable DMA Setup FIS Auto-Activate optimization |
| CAh | | Write DMA | EFh | 10h 03h | Enable Device-initiated interface power state (DIPM) transitions |
| CBh | | Write DMA without Retry | EFh | 10h 06h | Enable Software Settings Preservation (SSP) |
| CEh | | Write Multiple FUA EXT | EFh | 10h 07h | Enable Device Automatic Partial to Slumber transitions |
| E0h | | Standby Immediate | EFh | 10h 09h | Enable Device Sleep |
| E1h | | Idle Immediate | EFh | 55h | Disable read look-ahead feature |
| E2h | | Standby | EFh | 66h | Disable reverting to power-on defaults |
| E3h | | Idle | EFh | 82h | Disable write cache |
| E4h | | Read Buffer | EFh | 85h | Disable advanced power management |
| E5h | | Check Power Mode | EFh | 90h | Disable use of Serial ATA feature set |
| E6h | | Sleep | EFh | 90h 02h | Disable DMA Setup FIS Auto-Activate optimization |
| E7h | | Flush Cache | EFh | 90h 03h | Disable Device-initiated interface power state (DIPM) transitions |
| E8h | | Write Buffer | EFh | 90h 06h | Disable Software Settings Preservation (SSP) |
| E9h | | Read Buffer DMA | EFh | 90h 07h | Disable Device Automatic Partial to Slumber transitions |
| EAh | | Flush Cache EXT | EFh | 90h 09h | Disable Device Sleep |
| EBh | | Write Buffer DMA | EFh | AAh | Enable read look-ahead feature |
| EFh | CCh | Enable reverting to power-on defaults | F4h | | Security Erase Unit |
| F1h | | Security Set Password | F5h | | Security Freeze Lock |
| F2h | | Security Unlock | F6h | | Security Disable Password |
| F3h | | Security Erase Prepare | F8h | | Read Native Max Address |

6.2. Identify Device Data

The following table details the sector data returned by the IDENTIFY DEVICE command.

| Word | F: Fixed V: Variable X: Both | Default Value | Description |
|-------|------------------------------------|---------------|-------------------------------------------------------------------------------|
| 0 | F | 0040h | General configuration bit-significant information |
| 1 | X | *1 | Obsolete – Number of logical cylinders |
| 2 | V | C837h | Specific configuration |
| 3 | X | 0010h | Obsolete – Number of logical heads (16) |
| 4-5 | X | 00000000h | Retired |
| 6 | X | 003Fh | Obsolete – Number of logical sectors per logical track (63) |
| 7-8 | V | 00000000h | Reserved for assignment by the Compact Flash Association |
| 9 | X | 0000h | Retired |
| 10-19 | F | Varies | Serial number (20 ASCII characters) |
| 20-21 | X | 0000h | Retired |
| 22 | X | 0000h | Obsolete |
| 23-26 | F | Varies | Firmware revision (8 ASCII characters) |
| 27-46 | F | Varies | Model number (xxxxxxx) |
| 47 | F | 8010h | 7:0- Maximum number of sectors transferred per interrupt on MULTIPLE commands |
| 48 | F | 4000h | Reserved |
| 49 | F | 2F00h | Capabilities |
| 50 | F | 4000h | Capabilities |
| 51-52 | X | 00000000h | Obsolete |
| 53 | F | 0007h | Words 88 and 70:64 valid |
| 54 | X | *1 | Obsolete – Number of logical cylinders |
| 55 | X | 0010h | Obsolete – Number of logical heads (16) |
| 56 | X | 003Fh | Obsolete – Number of logical sectors per track (63) |
| 57-58 | X | *2 | Obsolete – Current capacity in sectors |
| 59 | F | 0110h | Number of sectors transferred per interrupt on MULTIPLE commands |
| 60-61 | F | *3 | Maximum number of sector (28bit LBA mode) |
| 62 | X | 0000h | Obsolete |
| 63 | F | 0407h | Multi-word DMA modes supported/selected |
| 64 | F | 0003h | PIO modes supported |
| 65 | F | 0078h | Minimum Multiword DMA transfer cycle time per word |

WellDisk Technology Co., Ltd.

layer 318 new material chuangye building Feng Hui middle road no.7 Beijing haidian district
 TEL: +86-010-56298618 E-mail: sales@welldisk.com

| Word | F: Fixed V: Variable X: Both | Default Value | Description |
|-------|------------------------------------|------------------------|---------------------------------------------------------------------------------------------------------------------------------|
| 66 | F | 0078h | Manufacturer's recommended Multiword DMA transfer cycle time |
| 67 | F | 0078h | Minimum PIO transfer cycle time without flow control |
| 68 | F | 0078h | Minimum PIO transfer cycle time with IORDY flow control |
| 69 | F | 5F20h | Additional Supported |
| 70 | F | 0000h | Reserved |
| 71-74 | F | 0000000000000000 0h | Reserved for the IDENTIFY PACKET DEVICE command |
| 75 | F | 001Fh | Queue depth |
| 76 | F | E70Eh | Serial SATA capabilities |
| 77 | F | 0006/0004/0002h | Supported Serial ATA Phy speed |
| 78 | F | 054Ch | Serial ATA features supported |
| 79 | V | 0040H | Serial ATA features enabled |
| 80 | F | 03F8h | Major Version Number |
| 81 | F | 0000h | Minor Version Number |
| 82 | F | 746Bh | Command set supported |
| 83 | F | 7D09h | Command set supported |
| 84 | F | 4163h | Command set/feature supported extension |
| 85 | V | 7469h | Command set/feature supported or enabled |
| 86 | V | BC09h | Command set/feature supported or enabled |
| 87 | V | 4163h | Command set/feature supported or enabled |
| 88 | V | 007Fh | Ultra DMA Modes |
| 89 | F | 0001h | Time required for Normal Erase mode SECURITY ERASE UNIT command |
| 90 | F | 0001h | Time required for an Enhanced Erase mode SECURITY ERASE UNIT command |
| 91 | V | 00FEh | Current advanced power management value |
| 92 | V | FFFEh | Master Password Revision Code |
| 93 | F | 0000h | Hardware reset result. The contents of the bits (12:0) of this word can be changed only during the execution of hardware reset. |
| 94 | V | 0000h | Vendor's recommended and actual acoustic management value |
| 95 | F | 0000h | Stream Minimum Request Size |

WellDisk Technology Co., Ltd.

layer 318 new material chuanyue building Feng Hui middle road no.7 Beijing haidian district TEL: +86-010-56298618 E-mail: sales@welldisk.com

| Word | F: Fixed V: Variable X: Both | Default Value | Description |
|---------|------------------------------------|--------------------------------------------------------|-------------------------------------------------------------------|
| 96 | V | 0000h | Streaming Transfer Time – DMA |
| 97 | V | 0000h | Streaming Access Latency – DMA and PIO |
| 98-99 | F | 0000h | Streaming Performance Granularity |
| 100-103 | V | *4 | Maximum user LBA for 48 bit Address feature set |
| 104 | V | 0000h | Streaming Transfer Time – PIO |
| 105 | F | 0008h | Maximum number of 512-byte blocks per DATA SET MANAGEMENT command |
| 106 | F | 4000h | Physical sector size/Logical sector size |
| 107 | F | 0000h | Inter-seek delay for ISO-7779 acoustic testing in microseconds |
| 108-111 | F | 0000000000000000 0h | Unique ID |
| 112-115 | F | 0000000000000000 0h | Reserved |
| 116 | V | 0000h | Reserved |
| 117-118 | F | 00000000h | Words per logical Sector |
| 119 | F | 401Ch | Supported settings |
| 120 | F | 401Ch | Command set/Feature Enabled/Supported |
| 121-126 | F | 0h | Reserved |
| 127 | F | 0h | Removable Media Status Notification feature set support |
| 128 | V | 0021h | Security status |
| 129-159 | X | 0h | Vendor specific |
| 160 | F | 0h | Compact Flash Association (CFA) power mode 1 |
| 161-167 | X | 0h | Reserved for assignment by the CFA |
| 168 | F | 3h 2.5 inch 4h 1.8 inch 5h Less than 1.8 inch | Device Nominal Form Factor |
| 169 | F | 0001h | DATA SET MANAGEMENT command is supported |
| 170-173 | F | 0h | Additional Product Identifier |
| 174-175 | | 0h | Reserve |
| 176-205 | V | 0h | Current media serial number |
| 206 | F | 0039h | SCT Command Transport(|
| 207-208 | F | 0h | Reserved |
| 209 | F | 4000h | Alignment of logical blocks within a physical block |

| Word | F: Fixed V: Variable X: Both | Default Value | Description |
|---------|------------------------------------|-------------------------|------------------------------------------------------------------------------------|
| 210-211 | V | 0000h | Write-Read-Verify Sector Count Mode 3 (not support) |
| 212-213 | F | 0000h | Write-Read-Verify Sector Count Mode 2 (not support) |
| 214-216 | | 0000h | NV Cache relate (not support) |
| 217 | F | 0001h | Non-rotating media device |
| 218 | F | 0h | Reserved |
| 219 | F | 0h | NV Cache relate (not support) |
| 220 | V | 0h | Write read verify feature set current mode |
| 221 | | 0h | Reserved |
| 222 | F | 107Fh | Transport major version number |
| 223 | F | 0h | Transport minor version number |
| 224-229 | | 0h | reserved |
| 230-233 | | 0h | Extend number of user addressable sectors |
| 234 | | 0001h | Minimum number of 512-byte data blocks per DOWNLOAD MICROCODE command for mode 03h |
| 235 | | FFFFh | Maximum number of 512-byte data blocks per DOWNLOAD MICROCODE command for mode 03h |
| 236-242 | F | 0h | Reserved |
| 243 | | 4000h | Security feature 4000 : Self Encrypting Drive |
| 244-254 | F | 0h | Reserved |
| 255 | X | XXA5h XX is variable | Integrity word (Checksum and Signature) |

■ **List of Device Identification for Each Capacity**

| Capacity (GB) | *1 (Word 1/Word 54) | *2 (Word 57-58) | *3 (Word 60-61) | *4 (Word 100-103) |
|------------------|------------------------|--------------------|--------------------|----------------------|
| 4 | 1E5Dh | 778E30h | 778E30h | 778E30h |
| 8 | 3CA5h | EEC9B0h | EEC9B0h | EEC9B0h |
| 16 | 3FFFh | FBFC10h | 1DD40B0h | 1DD40B0h |
| 32 | 3FFFh | FBFC10h | 3BA2EB0h | 3BA2EB0h |
| 64 | 3FFFh | FBFC10h | 7740AB0h | 7740AB0h |

7. PHYSICAL DIMENSION



Dimension: 29mm (L) x 28mm (W) x 7.84mm (H)

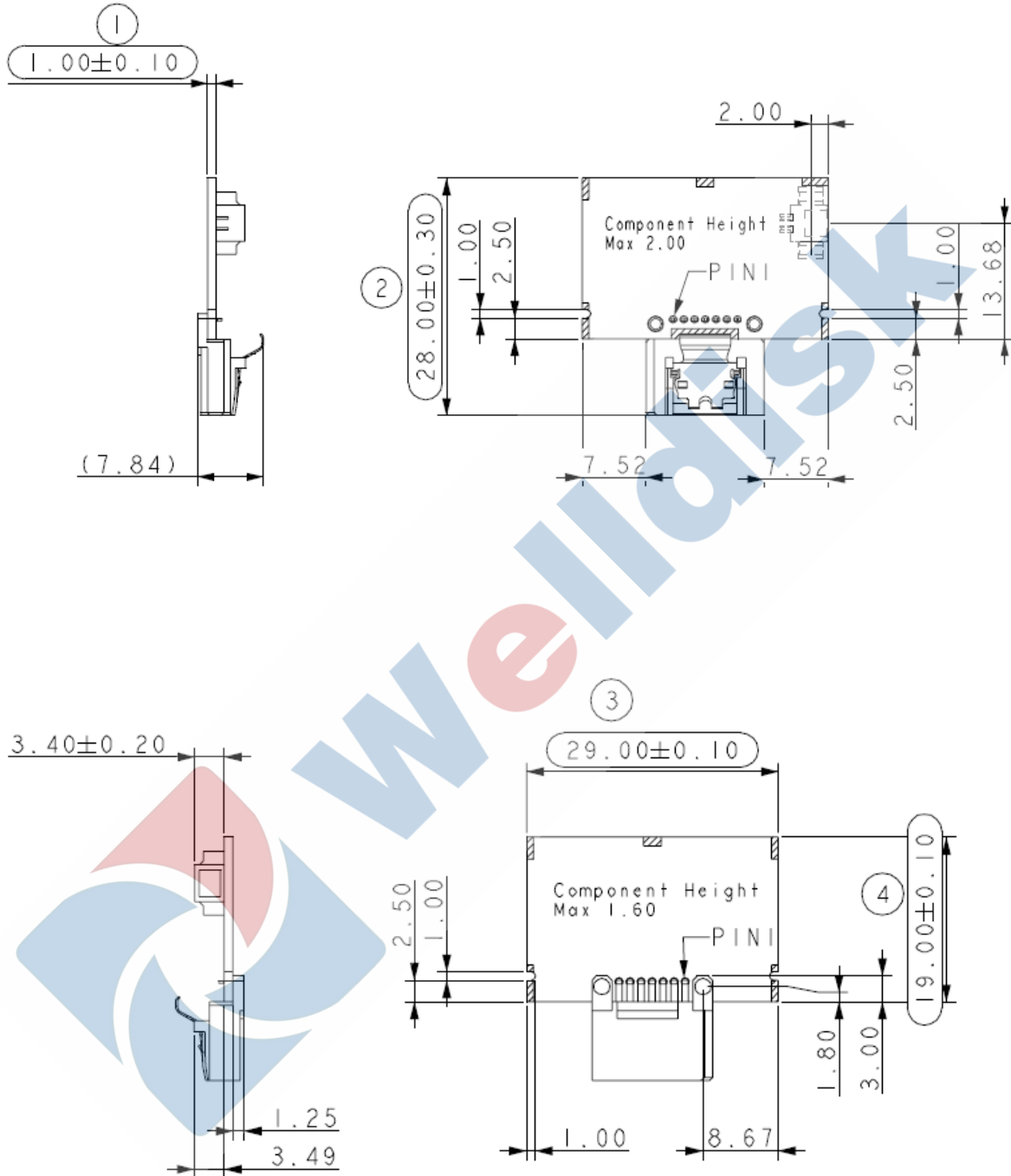

Welldisk Technology Co., Ltd.

layer 318 new material chuanyue building Feng Hui middle road no.7 Beijing hai dian district TEL: +86-010-56298618 E-mail: sales@welldisk.com

8. TERMINOLOGY



The following table is to list out the acronyms that have been applied throughout the document.

| Term | Definitions |
|------------|----------------------------------------------------|
| ATTO | Commercial performance benchmark application |
| DDR | Double data rate (SDRAM) |
| DIPM | Device initiated power management |
| HIPM | Host initiated power management |
| LBA | Logical block addressing |
| MB | Mega-byte |
| MTBF | Mean time between failures |
| NCQ | Native command queue |
| SATA | Serial advanced technology attachment |
| S.M.A.R.T. | Self-monitoring, analysis and reporting technology |
| SSD | Solid state disk |



9. PARTNUMBER DECODER**W SD S3 2 – XXXX X**